



SHIFT AEC SPECIFICATION

Plug & Play AEC for In-Rack Ethernet Applications in NIC-TOR

800G (8x112G) QSFP-DD PAM4 to 2x400G (4x112G) QSFP112 PAM4

CreDO's HiWire™ SHIFT Active Electrical Cable (SHIFT AEC)

A reliable, plug & play replacement of Active Optical Cable (AOC) for high-speed interconnects (up to 800Gbps). Intended for rack-to-rack connectivity, these cables support up to 2.5m reach, consume up to 75% less power than optics, cost up to 50% less than optics, and offer a 10- year service life.

CreDO's CAC8XX321M2N-B0-HW HiWire SHIFT AEC

Designed for telecom and data center use. It can sustain 8 lanes of 112G-PAM4 signal in each direction, and provides a breakout function to 2x400G QSFP-DD connectors with software selectable 4x112G operation. The use and replacement of CAC8XX321M2N-B0-HW AEC is simple and straightforward as it adopts standard QSFP-DD800 type 2 form factor and complies to MSA specifications.

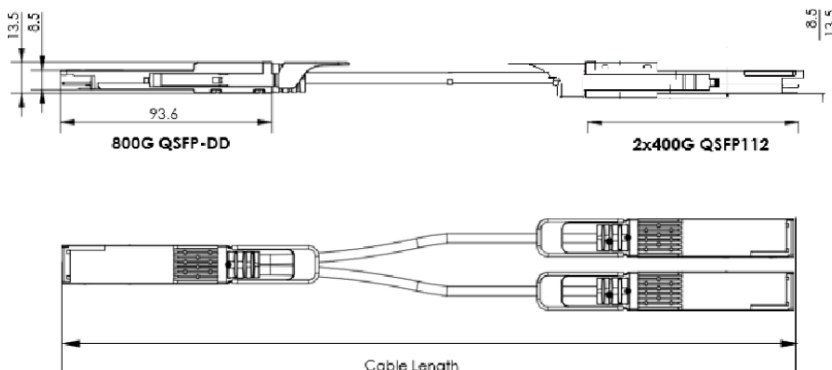

Features

The following are the key features of the HiWire LP SHIFT AEC:

- Recognizable, purple LSZH jacket
- 800G to 2X400G data rate
400G side- CMIS selectable
4x112G
- CMIS compliant
- Single 3.3V power supply
- Typ. 10W power dissipation per 800G side; 5W per 400G side
- BER < 10^{-15} (post FEC)
- Hot pluggable
- RoHS2 compliant
- I²C management interface
- Operating case temperature range: 0° to +70°C

Supported Standards and Interfaces

- Common Management Interface Specification (CMIS) v5.0
- QSFP-DD800 MSA v6.0

Key Features

Parameter	Value
Module Form Factor	QSFP-DD800 type 2 and QSFP112
Number of Data Lanes	800G Side: 8 TX and 8 RX per module (PAM4) 400G Side: 4 TX and 4 RX per module (PAM4)
Maximum Aggregate Data Rate	800Gbps
Nominal Data Rate per Lane	800G Side: 106.25Gbps (PAM4) 400G Side: 106.25Gbps (PAM4)
Electrical Interface and Pin-out	38-pin edge connector
Pin Description	Per QSFP-DD800 Hardware Specification
Management Interface	I ² C, serial, timing per Common Management Interface Specification for 8X/16X Pluggable Transceivers
Length of Copper AEC	0.5m – 2.5m
BER (Pre-FEC)*	Typ. <10 ⁻⁸
BER (Post-FEC)*	<10 ⁻¹⁵

* Tested with QPRBS31 pattern

Product Selections

Part Number	Length	AWG	Weight
CAC8XX321M2N-B0-HW	0.5-2.5m	32	350-550g

- Length available in 0.5m increment
- Weight increases by 50g for every 0.5m increment

Mechanicals

Parameter	Cable Type	Typical
Diameter	8P 32AWG	6.0mm
Minimum bend radius	8P 32AWG	18mm

About Credo

Credo's mission is to advance high-speed connectivity solutions that deliver optimized performance, reliability, energy efficiency, and security for the next generation of AI driven applications, cloud computing, and hyperscale networks.

Optimized for both optical and electrical applications, our solutions support port speeds up to 1.6Tb. At the core of our technology is our proprietary Serializer/Deserializer (SerDes) IP. Our diverse solutions portfolio includes system-level products such as Active Electrical Cables (AECs), a range of Integrated Circuits, including Retimers, Optical DSPs, SerDes chipsets, and SerDes IP Licensing.

For more information please visit www.credosemi.com or email sales@credosemi.com

© 2025 Credo Semiconductor, Inc. All Rights Reserved. Credo Semiconductor Inc. and the Credo logo are trademarks of Credo Semiconductor Inc. All other marks are the property of their respective owners. This document is for information only. Specifications are subject to change without notice.

REV 031225

