



PRODUCT BRIEF > OPTICAL

OPTICAL DSP

Dove 410D



400Gbps PAM-4 DSP with Integrated VCSEL Driver

Dove 410D (CFD43401) is a versatile full-duplex device with industry-leading power dissipation that is ideal for next-generation, low-power, high-performance 400G QSFP112 optical transceivers and AOCs.

The device includes industry's first monolithically integrated CMOS VCSEL drivers and fourth generation DSP technology which combined, creates an optimized, high-performance, small footprint solution that meets increasingly stringent energy efficiency requirements. The Dove 410D is tailored for multimode optical fiber (MMF) applications.

Dedicated PLLs for each transmit and receive data lane enable a wide range of breakout applications. High-performance optical and electrical host side DSP technology, together with specialized performance enhancing features, compensate for optical and electrical impairments while maintaining low power dissipation.

Applications

- AI
- Hyperscale data centers
- Cloud networks
- 400GbE optical transceivers and AOCs
- Breakout applications

Key Parameters

Host Side	4x106G PAM4
Line Side	4x106G PAM4
Operating Temp	0° to 85°C

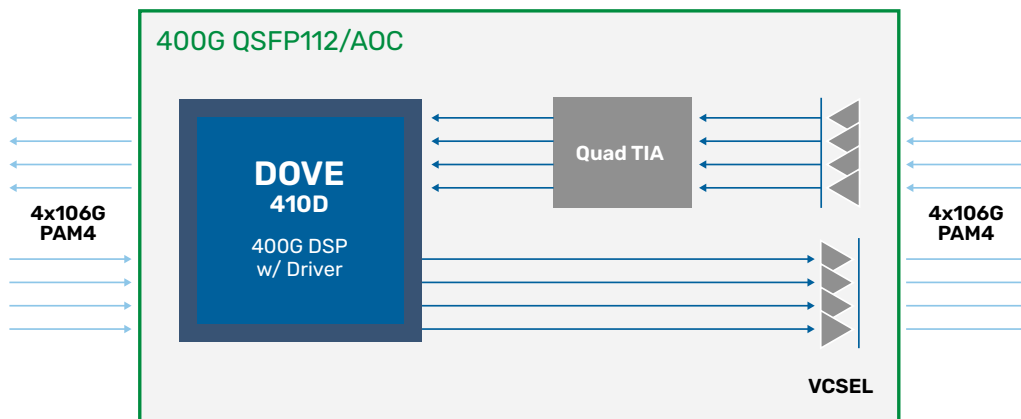

Key Features

- 100G PAM4 on both the electrical host and optical line side
- Fourth generation DSPs on optical side and electrical side deliver industry leading sensitivity and BER performance, providing margin for component variation and high-volume manufacturing
- Line side Rx performance-enhancing features tailored to address optical impairments in stressful MMF environment
- Integrated 100G VCSEL drivers with programmable laser currents to optimize module layout and reduce BOM costs
- High-performance transmitters come with multi-tap FIR filters, allowing precision optimization at both the module electrical connector and optical interface
- Host side interface supports extended PCB reach without the need for customized per-channel settings
- Independent phase locked loops per channel support flexible breakout configurations including 4x100G, 2x200G and 1x400G
- Full suite of test features and loopbacks simplifies lab bring up and production testing to reduce time-to-market
- Low-power dissipation enables higher rack utilization and lower thermal cooling requirements

Supported Standards and Interfaces

- 400G-SR4
- 400GAUI-4 C2M
- CEI-112G-VSR-PAM4
- CEI-112G-MR-PAM4
- QSFP112
- CMIS 4.x and 5.x

For more information please visit www.credosemi.com
or email sales@credosemi.com